

## Technical Data Sheet



Air



Ground



Water



Brine



Cooling



PV-ready



Modulation

### Brine/Water Heat Pump 8 – 20 kW - single phase 230V



#### Heliotherm Basic Comfort

A fully modulating brine/water heat pump, single phase with leading edge modulation technology automatically adjusts to the single or multi-family home's heating requirements. Centralized to this Seasonal Performance accomplishment is the heat pump's intelligent control. The result is a high accent of indoor climate and maximum living comfort. In combination with a photovoltaic system, in connection to a wide range of buffer storage units and heat delivery systems and optional cooling virtually renders unlimited planning realisation for your heating system.

#### Basic Comfort Advantages

- Minimal operating costs resulting from a SCOP of up to 5.5 (climate zone „medium“, temperature level of 35 °C)
- Quiet operation through acoustic decoupling and special insulation case design
- Ex-works integrated hydraulic block
- Safe and almost maintenance-free operation is obtained through the high quality construction and components
- Heliotherm's registered twin-x technology® and patented dsi-technology® for more efficiency from our environment's free energy



## Technical Data P/230V

Type Basic Comfort Modulating		08S10W	12S16W	20S25W
<b>Energy source (Primary cycle)</b>				
Content	Liter	1,9	1,9	3
Volume flow (temperature difference 4 K)	m <sup>3</sup> /h	3,9	4,2	5,5
Pressure loss	mWs	2,6	2,8	3,9
Min. outlet temperature	°C	-4	-4	-4
Max. outlet temperature	°C	20	20	20
<b>Heating water at 5 K temperature difference</b>				
Content	Liter	2,5	2,5	3,0
Volume flow (temperature difference 5 K)	Liter/h	1,0 - 2,0	1,0 - 2,9	1,8 - 3,9
Pressure loss	mWs	1	1,6	2,1
Max. outlet temperature	°C	65	65	65
Hydraulic block		BC-HYD14	BC-HYD14	BC-HYD16
Pressure head heating	mWs	5,2	2,7	4,1
Pressure head energy source	mWs	3,6	3,1	0,8
<b>Electric values</b>				
Nominal voltage		1/N/PE 230 V/50 Hz	1/N/PE 230 V/50 Hz	1/N/PE 230 V/50 Hz
Max. nominal voltage	A	21	25	31,5
Starting current	A	10	12	15
Fuse protection - slow	A	25	32	40
Nominal control circuit		1/N/PE 230 V/50 Hz	1/N/PE 230 V/50 Hz	1/N/PE 230 V/50 Hz
Protection control circuit	A	13	13	13
Protection class		63 A/300 mA	63 A/300 mA	63 A/300 mA
<b>Refrigerant cycle</b>				
Working fluid		R-410A	R-410A	R-410A
Fill amount	kg	4,3	4,8	5,0
Fill amount for reversible (optional)	kg	4,6	5,1	5,3
Compressor	Type	Scroll	Scroll	Scroll
Compressor speed	1/min	1200 - 5400	1200 - 5400	1200 - 5400
Oil amount	Liter	1,3	1,7	2,3
<b>Dimensions</b>				
Total length	mm	670	670	670
Total width	mm	600	600	600
Total height	mm	1.700	1.700	1.700
<b>Total weight</b>	kg	215	218	221
<b>Permitted operating pressure</b>	bar	10	10	10
<b>Connections</b>				
Heating water outlet and inlet	OT	5/4"	5/4"	5/4"
Brine outlet and inlet	OT	5/4"	5/4"	5/4"
<b>Nitrous oxide committee NO<sub>x</sub></b>	mg / kWh	0	0	0



**Acoustic Technical Data acc. to EN 12102 P/230V**

**Type Basic Comfort Modulating**

**A-Assesed acoustic capacity & level  
in heating mode at B0(±3 K)/W55 (±1 K)**

Nominal heat output

dB(A)

08S10W

12S16W

20S15W

42

45

47



Basic Comfort Brine/Water Heat Pump Modulating  
8 – 20 kW - P/230V

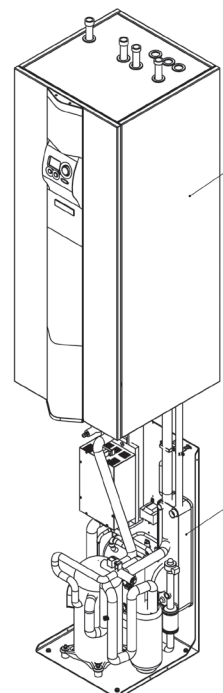
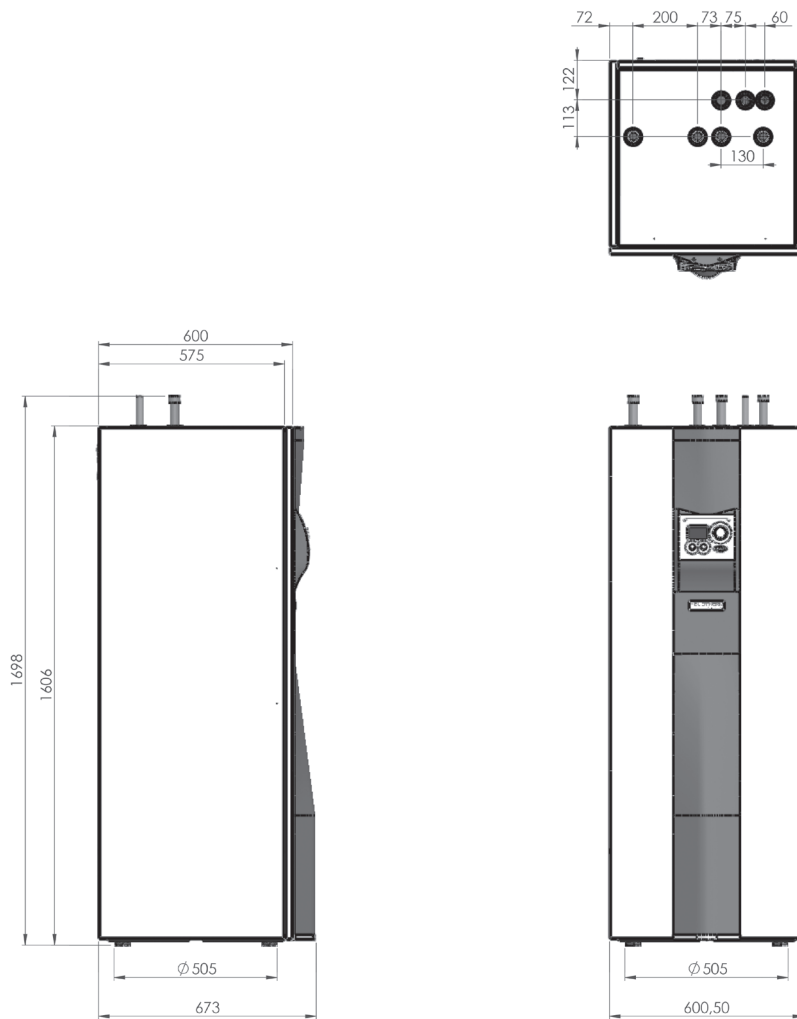

**Performance Data HP08S10W-M-BC P/230V**

acc. to EN14825 (calculated values; errors reserved)

**Seasonal room heating - Energy efficiency class A+++**

Full Load and Seasonal Performance Factor in heating mode

Climate zone	Outlet temperature level	P <sub>designh</sub> [kW]	Q <sub>HE</sub> [kWh]	SCOP	η <sub>s</sub> [%]
medium (Strasbourg)	low (35°C)	8	2146	5,22	206
	medium (45°C)	8	2593	4,32	170
	high (55°C)	8	3088	3,63	142
warmer (Athens)	low (35°C)	8	2163	5,18	204
	medium (45°C)	8	2426	4,62	182
	high (55°C)	8	2859	3,92	154
colder (Helsinki)	low (35°C)	8	3240	5,19	204
	medium (45°C)	8	3861	4,35	171
	high (55°C)	8	4618	3,64	143

Full load in cooling mode for ceiling cooling applications  
SPF in cooling mode for ceiling cooling applications

P<sub>designc</sub> = 8 kW  
SEER = 7,12

Full load in cooling mode for convector fans  
SPF in cooling mode for convector fans

P<sub>designc</sub> = 8 kW  
SEER = 6,50



## Performance Data HP08S10W-M-BC P/230V (Continued)

Partial loads and COPs for the reference heating period, „medium“ (Strasbourg)

Temperature level	Operating point	Partial load ratio [%]	Heating capacity P <sub>dh</sub> [kW]	COP <sub>d</sub>
low (35°C)	B0/W24	15	1,24	5,49
	B0/W27	35	2,81	5,47
	B0/W30	54	4,35	5,14
	B0/W34	88	7,08	4,93
	B0/W35	100	8,48	4,93
medium (45°C)	B0/W28	15	1,18	5,01
	B0/W33	35	2,79	4,43
	B0/W37	54	4,40	4,30
	B0/W43	88	7,15	3,99
	B0/W45	100	8,33	3,85
high (55°C)	B0/W30	15	1,24	4,37
	B0/W36	35	2,84	3,84
	B0/W42	54	4,39	3,67
	B0/W52	88	7,17	2,98
	B0/W55	100	8,34	2,86

Partial loads and COPs for the reference heating period, „warmer“ (Athens)

Temperature level	Operating point	Partial load ratio [%]	Heating capacity P <sub>dh</sub> [kW]	COP <sub>d</sub>
low (35°C)	B0/W26	29	2,30	5,33
	B0/W31	64	5,34	5,10
	B0/W35	100	8,48	4,93
medium (45°C)	B0/W31	29	2,42	4,95
	B0/W39	64	5,34	4,41
	B0/W45	100	8,33	3,88
high (55°C)	B0/W34	29	2,32	4,45
	B0/W46	64	5,27	3,57
	B0/W55	100	8,34	2,86



## Performance Data HP08S10W-M-BC P/230V (Continued)

Partial loads and COPs for the reference heating period, „colder“ (Helsinki)

Temperature level	Operating point	Partial load ratio [%]	Heating capacity $P_{dh}$ [kW]	COP <sub>d</sub>
low (35°C)	B0/W24	11	1,09	4,99
	B0/W25	24	1,94	5,48
	B0/W27	37	2,98	5,29
	B0/W30	61	5,33	5,09
	B0/W35	100	8,48	4,93
medium (45°C)	B0/W26	11	1,13	4,84
	B0/W30	24	1,90	4,78
	B0/W33	37	2,95	4,37
	B0/W38	61	5,34	4,25
	B0/W45	100	8,33	3,85
high (55°C)	B0/W28	11	1,18	4,59
	B0/W32	24	1,95	4,23
	B0/W37	37	2,99	3,80
	B0/W44	61	5,29	3,38
	B0/W55	100	8,34	2,86

Partial loads and COPs in cooling mode for ceiling cooling applications <sup>(a)</sup>

Operating point	Partial load ratio [%]	Cooling capacity $P_{dc}$ [kW]	EER <sub>d</sub>
B10/W18	21	5,30	7,12
B10/W18	47	5,51	7,39
B10/W18	74	6,10	7,78
B10/W18	100	8,09	7,87

Partial loads and COPs in cooling mode for cooling mode for convector fans <sup>(a)(b)</sup>

Operating point	Partial load ratio [%]	Cooling capacity $P_{dc}$ [kW]	EER <sub>d</sub>
B10/W11,5	21	5,11	6,64
B10/W10	47	5,29	6,93
B10/W8,5	74	6,23	6,79
B10/W7	100	8,09	6,37

<sup>(a)</sup> Operational use only with a hydraulic accumulation at a condensing temperature of 20 (B10/W7) to 30 °C (B10/W18)!

<sup>(b)</sup> Cooling temperatures below 15 °C only after consultation with Heliotherm.



**Performance Data HP12S16W-M-BC P/230V**

acc. to EN14825 (calculated values; errors reserved)

**Seasonal room heating - Energy efficiency class A+++**

Full Load and Seasonal Performance Factor in heating mode

Climate zone	Outlet temperature level	P <sub>designh</sub> [kW]	Q <sub>HE</sub> [kWh]	SCOP	η <sub>s</sub> [%]
medium (Strasbourg)	low (35°C)	12	3159	5,32	210
	medium (45°C)	12	3822	4,40	173
	high (55°C)	12	4499	3,73	146
warmer (Athens)	low (35°C)	12	3192	5,26	208
	medium (45°C)	12	3696	4,55	179
	high (55°C)	12	4536	3,70	145
colder (Helsinki)	low (35°C)	12	4670	5,40	213
	medium (45°C)	12	5940	4,24	167
	high (55°C)	12	6540	3,85	151

Full load in cooling mode for ceiling cooling applications  
SPF in cooling mode for ceiling cooling applications

P<sub>designc</sub> = 12 kW  
SEER = 6,75

Full load in cooling mode for convector fans  
SPF in cooling mode for convector fans

P<sub>designc</sub> = 12 kW  
SEER = 6,15





## Performance Data HP12S16W-M-BC P/230V (Continued)

Partial loads and COPs for the reference heating period, „medium“ (Strasbourg)

Temperature level	Operating point	Partial load ratio [%]	Heating capacity P <sub>dh</sub> [kW]	COP <sub>d</sub>
low (35°C)	B0/W24	15	6,96	5,66
	B0/W27	35	7,20	5,64
	B0/W30	54	6,56	5,21
	B0/W34	88	10,66	5,04
	B0/W35	100	12,07	5,16
medium (45°C)	B0/W28	15	7,05	4,89
	B0/W33	35	4,28	4,55
	B0/W37	54	6,53	4,41
	B0/W43	88	10,70	3,98
	B0/W45	100	12,05	3,82
high (55°C)	B0/W30	15	7,08	4,12
	B0/W36	35	4,24	4,09
	B0/W42	54	6,58	3,73
	B0/W52	88	10,61	3,12
	B0/W55	100	12,05	2,91

Partial loads and COPs for the reference heating period, „warmer“ (Athens)

Temperature level	Operating point	Partial load ratio [%]	Heating capacity P <sub>dh</sub> [kW]	COP <sub>d</sub>
low (35°C)	B0/W26	29	6,98	5,36
	B0/W31	64	7,71	5,21
	B0/W35	100	12,07	5,16
medium (45°C)	B0/W31	29	7,07	4,74
	B0/W39	64	7,75	4,51
	B0/W45	100	12,05	3,82
high (55°C)	B0/W34	29	3,49	4,16
	B0/W46	64	7,73	3,36
	B0/W55	100	12,05	2,91



## Performance Data HP12S16W-M-BC P/230V (Continued)

Partial loads and COPs for the reference heating period, „colder“ (Helsinki)

Temperature level	Operating point	Partial load ratio [%]	Heating capacity P <sub>dh</sub> [kW]	COP <sub>d</sub>
low (35°C)	B0/W24	11	6,98	5,20
	B0/W25	24	6,97	5,71
	B0/W27	37	4,58	5,51
	B0/W30	61	7,25	5,29
	B0/W35	100	12,07	5,16
medium (45°C)	B0/W26	11	7,04	4,46
	B0/W30	24	7,07	4,54
	B0/W33	37	4,49	4,29
	B0/W38	61	7,34	4,16
	B0/W45	100	12,05	3,82
high (55°C)	B0/W28	11	7,06	4,69
	B0/W32	24	2,90	4,23
	B0/W37	37	4,49	4,07
	B0/W44	61	7,36	3,61
	B0/W55	100	12,05	2,91

Partial loads and COPs in cooling mode for ceiling cooling applications <sup>(a)</sup>

Operating point	Partial load ratio [%]	Cooling capacity P <sub>dc</sub> [kW]	EER <sub>d</sub>
B10/W18	21	2,73	6,37
B10/W18	47	5,69	6,93
B10/W18	74	9,08	7,46
B10/W18	100	12,20	7,45

Partial loads and COPs in cooling mode for cooling mode for convector fans <sup>(a)(b)</sup>

Operating point	Partial load ratio [%]	Cooling capacity P <sub>dc</sub> [kW]	EER <sub>d</sub>
B10/W11,5	21	2,68	5,82
B10/W10	47	5,72	6,29
B10/W8,5	74	8,94	6,77
B10/W7	100	11,98	6,78

<sup>(a)</sup> Operational use only with a hydraulic accumulation at a condensing temperature of 20 (B10/W7) to 30 °C (B10/W18)!

<sup>(b)</sup> Cooling temperatures below 15 °C only after consultation with Heliotherm.



**Performance Data HP20S25W-M-BC P/230V**

acc. to EN14825 (calculated values; errors reserved)

**Seasonal room heating - Energy efficiency class A+++**

Full Load and Seasonal Performance Factor in heating mode

Climate zone	Outlet temperature level	P <sub>designh</sub> [kW]	Q <sub>HE</sub> [kWh]	SCOP	η <sub>s</sub> [%]
medium (Strasbourg)	low (35°C)	20	5053	5,56	219
	medium (45°C)	20	6055	4,62	182
	high (55°C)	20	7069	3,96	155
warmer (Athens)	low (35°C)	20	5108	5,48	216
	medium (45°C)	20	5894	4,75	187
	high (55°C)	20	6888	4,07	160
colder (Helsinki)	low (35°C)	20	7475	5,62	222
	medium (45°C)	20	8913	4,71	185
	high (55°C)	20	10322	4,07	160

Full load in cooling mode for ceiling cooling applications  
SPF in cooling mode for ceiling cooling applications

P<sub>designc</sub> = 20 kW  
SEER = 6,81

Full load in cooling mode for convector fans  
SPF in cooling mode for convector fans

P<sub>designc</sub> = 20 kW  
SEER = 6,22

**Power consumption in modes other than the operating mode**

Off mode P <sub>OFF</sub>	3,88 W
Temperature controller Off P <sub>TO</sub>	4,69 W
Standby mode P <sub>SB</sub>	4,69 W
Operating condition with crankcase heater P <sub>CK</sub>	- W



## Performance Data HP20S25W-M-BC P/230V (Continued)

Partial loads and COPs for the reference heating period, „medium“ (Strasbourg)

Temperature level	Operating point	Partial load ratio [%]	Heating capacity P <sub>dh</sub> [kW]	COP <sub>d</sub>
low (35°C)	B0/W24	15	5,59	5,91
	B0/W27	35	7,56	5,77
	B0/W30	54	11,43	5,46
	B0/W34	88	17,74	5,22
	B0/W35	100	20,11	4,94
medium (45°C)	B0/W28	15	5,44	5,25
	B0/W33	35	7,43	4,74
	B0/W37	54	11,30	4,59
	B0/W43	88	17,82	4,24
	B0/W45	100	20,19	4,06
high (55°C)	B0/W30	15	5,34	4,54
	B0/W36	35	7,41	4,29
	B0/W42	54	11,37	4,00
	B0/W52	88	17,60	3,19
	B0/W55	100	20,17	3,06

Partial loads and COPs for the reference heating period, „warmer“ (Athens)

Temperature level	Operating point	Partial load ratio [%]	Heating capacity P <sub>dh</sub> [kW]	COP <sub>d</sub>
low (35°C)	B0/W26	29	5,52	5,54
	B0/W31	64	13,20	5,46
	B0/W35	100	20,11	4,94
medium (45°C)	B0/W31	29	5,31	5,00
	B0/W39	64	13,25	4,59
	B0/W45	100	20,19	4,06
high (55°C)	B0/W34	29	5,39	4,59
	B0/W46	64	13,29	3,72
	B0/W55	100	20,17	3,06



## Performance Data HP20S25W-M-BC P/230V (Continued)

Partial loads and COPs for the reference heating period, „colder“ (Helsinki)

Temperature level	Operating point	Partial load ratio [%]	Heating capacity P <sub>dh</sub> [kW]	COP <sub>d</sub>
low (35°C)	B0/W24	11	5,57	5,39
	B0/W25	24	5,55	5,94
	B0/W27	37	7,57	5,73
	B0/W30	61	12,97	5,51
	B0/W35	100	20,11	5,26
medium (45°C)	B0/W26	11	5,50	5,10
	B0/W30	24	5,31	5,13
	B0/W33	37	7,54	4,77
	B0/W38	61	12,87	4,61
	B0/W45	100	20,19	4,06
high (55°C)	B0/W28	11	5,44	5,03
	B0/W32	24	5,26	4,59
	B0/W37	37	7,43	4,31
	B0/W44	61	12,68	3,79
	B0/W55	100	20,17	3,06

Partial loads and COPs in cooling mode for ceiling cooling applications <sup>(a)</sup>

Operating point	Partial load ratio [%]	Cooling capacity P <sub>dc</sub> [kW]	EER <sub>d</sub>
B10/W18	21	16,21	6,62
B10/W18	47	17,35	7,06
B10/W18	74	17,91	7,26
B10/W18	100	20,35	7,50

Partial loads and COPs in cooling mode for cooling mode for convector fans <sup>(a)(b)</sup>

Operating point	Partial load ratio [%]	Cooling capacity P <sub>dc</sub> [kW]	EER <sub>d</sub>
B10/W11,5	21	15,65	6,17
B10/W10	47	16,66	6,62
B10/W8,5	74	18,31	6,34
B10/W7	100	20,35	6,07

<sup>(a)</sup> Operational use only with a hydraulic accumulation at a condensing temperature of 20 (B10/W7) to 30 °C (B10/W18)!

<sup>(b)</sup> Cooling Temperatures below 15 °C only after consultation with Heliotherm.

